

(No Model.)

2 Sheets—Sheet 1.

I. F. KEARNS, F. BAIER & C. F. WEBER.

Spinning Lathe.

No. 240,145.

Patented April 12, 1881.

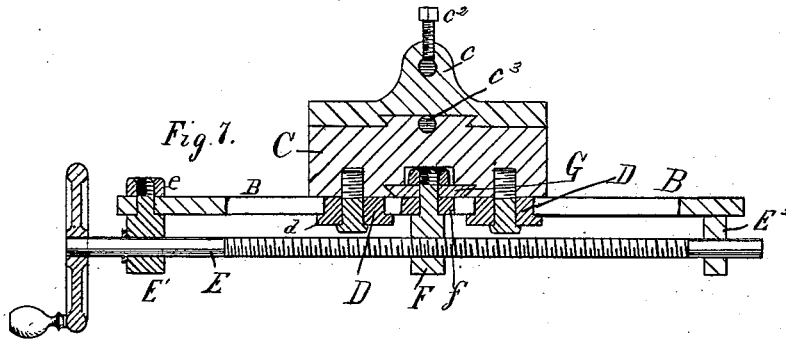
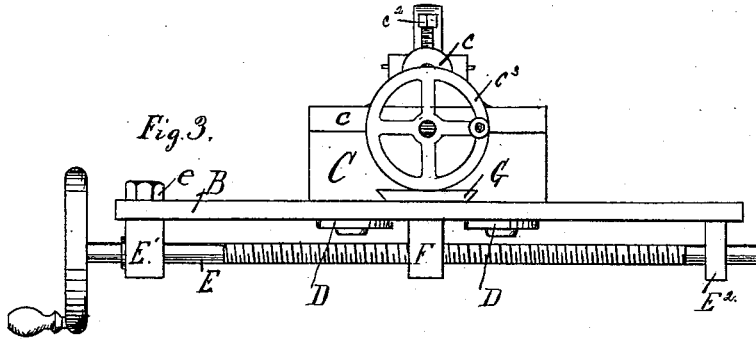
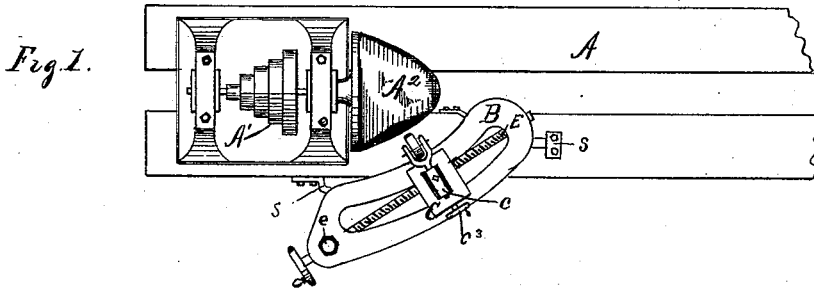

WITNESSES:  
*H. Brown*  
*E. M. ...*

INVENTOR:  
 Isaac F. Kearns  
 Frank Baier and  
 Chas. F. Weber by  
 Munday, Evans & Ascock  
 their attys.

(No Model.)

2 Sheets—Sheet 2.

I. F. KEARNS, F. BAIER & C. F. WEBER.

Spinning Lathe.

No. 240,145.

Patented April 12, 1881.

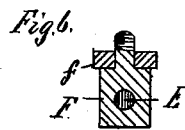
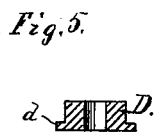
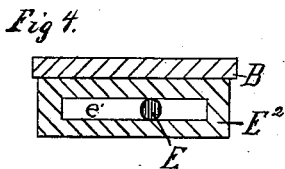
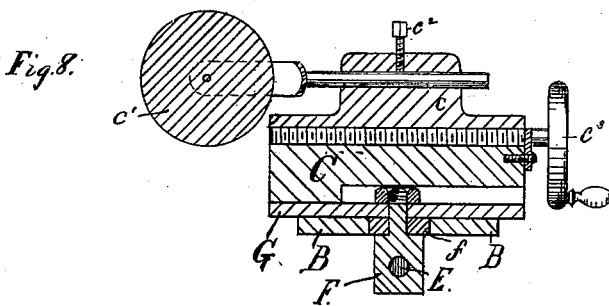
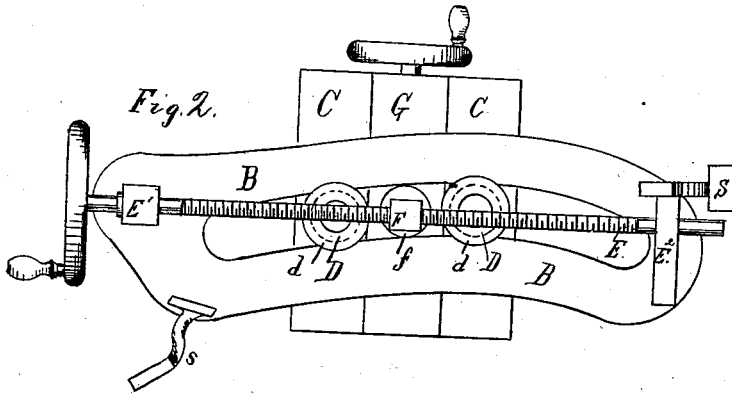

WITNESSES:  
*H. Brown*  
*Ed. Crawford*

INVENTOR:  
 Isaac F. Kearns  
 Frank Baier and  
 Chas. F. Weber  
 by Munday Evans & Woodcock  
 their attys

# UNITED STATES PATENT OFFICE.

ISAAC F. KEARNS, FRANK BAIER, AND CHARLES F. WEBER, OF CHICAGO,  
ILLINOIS, ASSIGNORS TO SAID KEARNS AND WEBER.

## SPINNING-LATHE.

SPECIFICATION forming part of Letters Patent No. 240,145, dated April 12, 1881.

Application filed January 10, 1881. (No model.)

To all whom it may concern:

Be it known that we, ISAAC F. KEARNS, FRANK BAIER, and CHARLES F. WEBER, all of Chicago, in the county of Cook and State of Illinois, have invented certain Improvements in Spinning-Lathes, of which the following is a specification.

This invention relates to the devices for guiding the tool-carriage in spinning-lathes, wherein it is desired to form spherical, paraboloidal, or other curved surfaces in articles of sheet metal.

The nature of the invention lies in the manner in which the motion of the tool-carriage is controlled as to direction; and it consists in the novel construction and combination of the parts, as hereinafter described.

In the accompanying drawings, Figure 1 is a plan of a lathe to which our improvement has been attached. Fig. 2 is a bottom view of the carriage and slideway. Fig. 3 is an elevation of the carriage, the guideway, and the feed-screw. Fig. 4 is a detail view of the slotted support provided for the outer or free end of the feed-screw. Figs. 5 and 6 are detail views of the feed foot and rollers attached to the carriage. Figs. 7 and 8 are respectively longitudinal and transverse sectional views through the carriage and slideway.

In the drawings, A represents the bed of the lathe, A' the pulleys thereof, and A<sup>2</sup> a form or mold secured thereto, and representing the shape to be given to the article to be spun. In the drawings this part A<sup>2</sup> is shown as a paraboloid; but it may be spherical, conoidal, or any similar form not requiring abrupt changes in the line to be followed by the spinning-tool.

Secured upon the lathe-bed by any proper supports, as s, is a curved slideway, B, the curve whereof corresponds to the curve of the form A<sup>2</sup>—that is to say, to the outer line of a section taken upon the axial line of the form. Upon this slideway the tool-carriage C is reciprocated, and it is given a fixed and positive path of travel in the said slideway by the vertical rollers D depending from the carriage and revolving along the sides of the slot in the slideway. These rollers have bottom flanges,

d, which project beyond the opening in the guideway, and thus serve to hold the carriage down firmly. The diameter of the rollers approaches the width of the slide-opening, as nearly as may be, without creating unnecessary friction, for obvious reasons.

At one end of the slideway is attached the feed-screw E by a head, E', held by a bolt, e, or equivalent device, which will act as a pivot and allow a limited swiveling by the screw upon it. Depending from the other end of the guideway is a support, E<sup>2</sup>, having a horizontal slot, e', within which the other end of the feed-screw rests. The feed-screw passes through a threaded opening in the foot F depending from the carriage, and reciprocates the carriage by means of said foot. That part of the foot within the vertical dimensions of the slideway is surrounded by a freely-rotating washer or roller, f, which, like the rollers D, fills the slot and serves to keep the foot and feed-screw centrally in the path at all points, so that the force of the screw is exerted in a line parallel to the direction of the path, as nearly as may be, at all times. The foot F is held to a slide, G, in the bottom of the carriage by a thread and nut upon its shaft portion. The slide permits it to change position by yielding in either direction, whenever necessary, to prevent its binding against the sides of the slideway B, and the thread-and-nut fastening permits it to turn as the changes in the line of the screw prompt or require.

The carriage is provided with the usual tool-holder, c, carrying a spinning-roller, c', and with the ordinary adjusting-screws c<sup>2</sup> and c<sup>3</sup>. The rotation of the feed-screw forces the carriage along the guideway, which, as already stated, is constructed to conform to the surface of the form to which the metal is to be spun. As it proceeds in said path the feed-screw accommodates itself to the changes in the line of movement by swinging laterally upon its swiveled end fastening, the slight swiveling of the foot F, the movement of the slide G, and the provision of the elongated slot e' permitting this operation of the screw.

Our invention permits the automatic performance of many operations in spinning here-

tofore always done by tools held in the hand of the workman. It may be used in burnishing, polishing, and turning lathes by substituting appropriate tools for those kinds of work, and the feed-screw may be geared to the lathe, so as to be automatic, if desired. And for some purposes the invention may be used where the form to be imparted or to be operated upon has hollows or concave portions.

10 We have shown no method of securing the blanks to be spun upon the lathe, as that is well understood by those skilled in the art.

We claim—

15 1. The combination, with a lathe, of the curved slideway, the tool-carriage traversing said slideway, and the rollers depending from the carriage and guiding it along the slideway, substantially as set forth.

2. In a lathe, the combination, with the tool-

carriage, of a curved slideway conforming to the mold or article to be formed and determining the path of the carriage, a screw for feeding the carriage along said slideway, secured at one end only by a swiveling attachment, and a foot on the carriage engaging the feed-screw, substantially as specified.

3. The combination, with the tool-carriage traversing a curved slideway, substantially as shown, of a feed-screw secured at one end by a swiveling attachment, and a foot engaging said screw and secured to a slide in the carriage, substantially as set forth.

ISAAC F. KEARNS.

FRANK BAIER.

CHAS. F. WEBER.

Witnesses:

EDW. S. EVARTS,

EVERETT BROWN.